

Light Emitting Diode

Product Characteristics:

- Ultra Bright Brightness
- 5mm Diameter Circular Shape Package
- General Purpose Lead
- Highly Reliable
- Emitting Color : Red

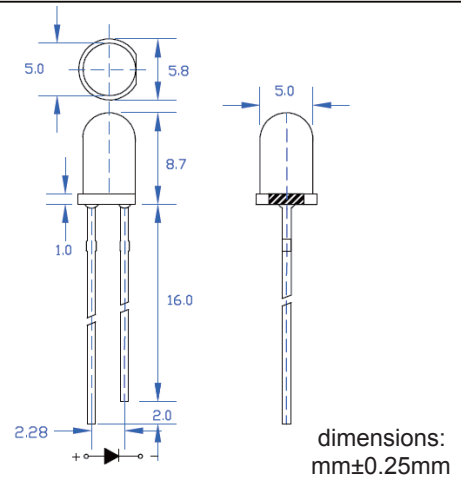

MAXIMUM RATINGS AND CHARACTERISTICS

@ 25°C Ambient Temperature (unless otherwise noted)

Parameter	MAX	Unit
Power Dissipation	70	mW
Continuous Forward Current	20	mA
Reverse Voltage	5	V
Operating Temperature Range	-30°C To +85°C	
Storage Temperature Range	-40°C To +100°C	
Lead Soldering Temperature (4mm(0.157")From Body)	260°C for 3seconds	

Electrical Specification (TA=25°C unless otherwise specified)

Parameter	Symbol	Min	Typ	Max.	Unit	Test Condition
Luminous Intensity	I _v	700	-----	1200	mcd	IF=20mA
Viewing Angle	2θ _{1/2}	-----	30	-----	Deg	IF=20mA
Peak Wavelength	λ _p	-----	634	-----	nm	IF=20mA
Forward Voltage	V _F	1.9	-----	2.4	V	IF=20mA
Reverse Current	I _R	-----	-----	5	μA	VR=5V

Notes:

1. Luminous intensity is measured with a light sensor and filter combination that approximates the CIE eye-response curve.
2. 2θ_{1/2} is the off-axis angle at which the luminous intensity is half the axial luminous intensity

RATINGS AND CHARACTERISTIC CURVES

Relative Intensity VS. Wavelength

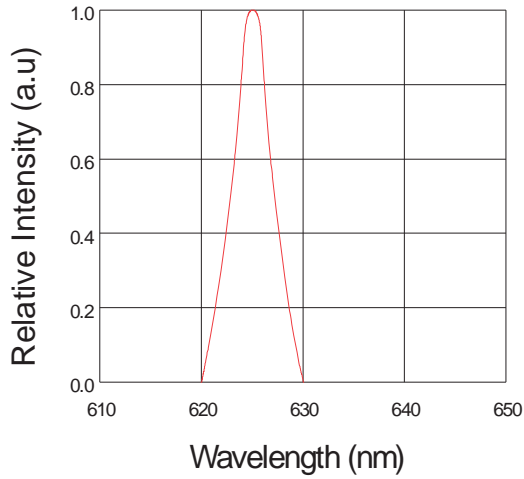

Forward Current VS. Forward Voltage

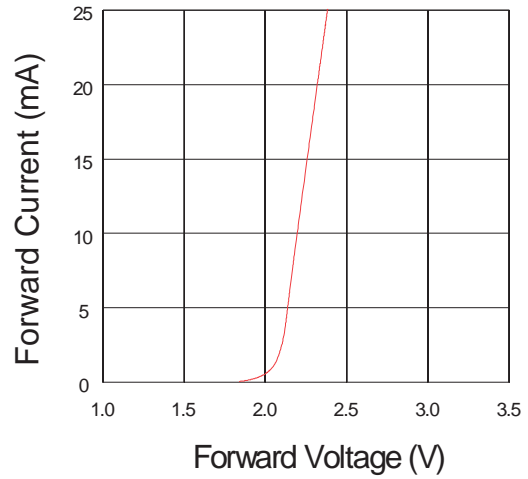

Relative Intensity VS. Ambient Temp

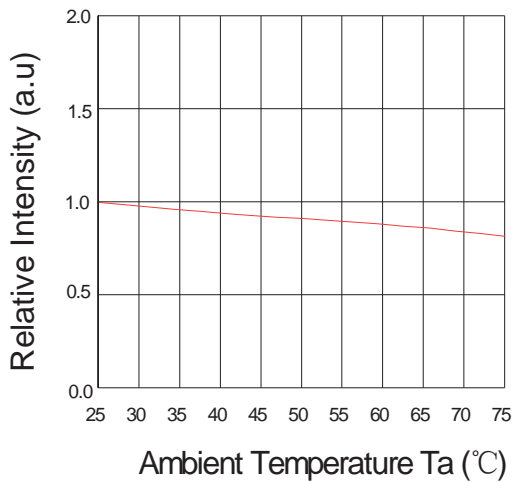

Forward Current VS. Relative Intensity

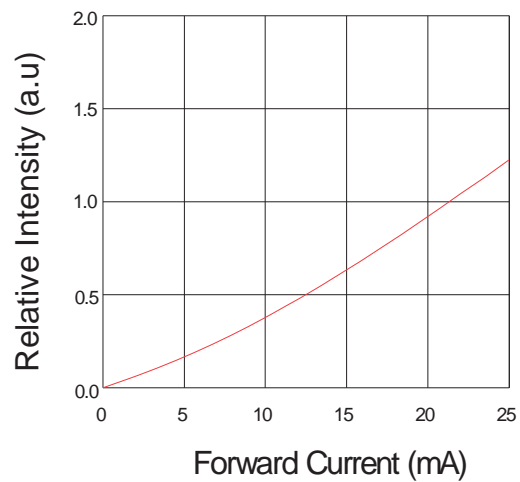

Forward Current VS. Ambient Temp.

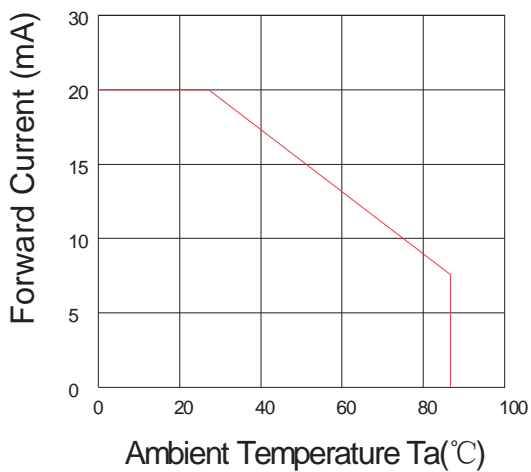

Radiation Characteristics

